

# DESIGN NOTES

## LT1880 SOT-23 Superbeta Op Amp Saves Board Space in Precision Applications – Design Note 266

Glen Brisebois

### INTRODUCTION

The tiny new LT<sup>®</sup>1880 achieves precision unprecedented in a SOT-23 package without resorting to autozeroing techniques. Input offset voltage and drift are typically 40 $\mu$ V and 0.3 $\mu$ V/ $^{\circ}$ C, respectively, with guarantees of 200 $\mu$ V and 1.2 $\mu$ V/ $^{\circ}$ C maximum over temperature. The device operates on total supplies from 2.7V to 40V with rail-to-rail outputs, giving a dynamic range of 120dB. Unlike some competitors' SOT-23 op amps, which claim to maintain good precision, the LT1880 supports its input precision with a high open loop gain of 1.6 million, as well as 135dB CMRR and PSRR. It is available in commercial and industrial temperature grades.

### APPLICATIONS

#### Getting Rail-to-Rail Operation without Rail-to-Rail Inputs

The LT1880 does not have rail-to-rail inputs, but for most inverting applications and noninverting gain applications, this is largely inconsequential. Figure 1 shows the basic op amp configurations, what happens to the op amp inputs, and whether or not the op amp must have rail-to-rail inputs.

The circuit of Figure 2 shows an extreme example of the inverting case. The input voltage at the 1M resistor can swing  $\pm 13.5$ V and the LT1880 will output an inverted,

divided-by-ten version of the input voltage. The gain accuracy is limited by the resistors to 0.2%. Output referred, this error becomes 2.7mV at 1.35V output. The 40 $\mu$ V input offset voltage contribution, plus the additional error due to input bias current times the  $\sim 100$ k effective source impedance, contribute negligible error.

#### Precision Photodiode Amplifier

Photodiode amplifiers usually employ JFET op amps because of their low bias current; however, when precision is required, JFET op amps are generally inadequate due to their relatively high input offset voltage and drift. The LT1880 provides a high degree of precision with very low bias current ( $I_B = 150$ pA typical) and is therefore

LTC and LT are registered trademarks of Linear Technology Corporation.

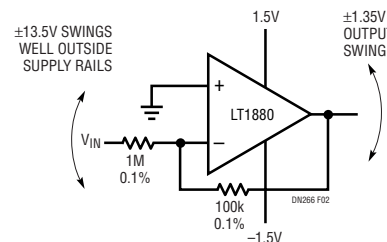

**Figure 2. Extreme Inverting Case: Circuit Operates Properly with Input Voltage Swing Well Outside Op Amp Supply Rails**

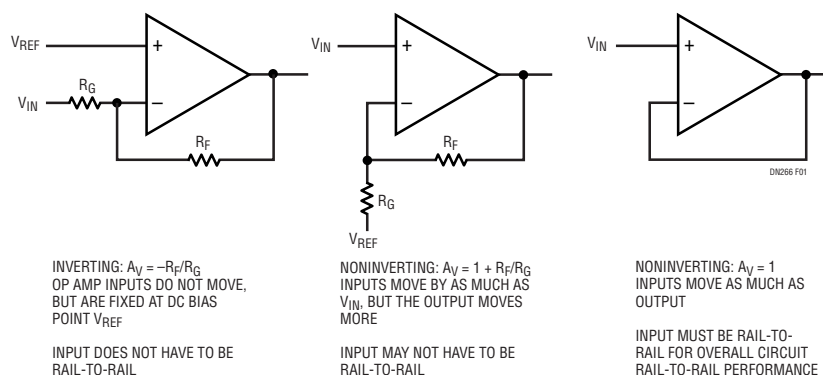

**Figure 1. Some Op Amp Configurations Do Not Require Rail-to-Rail Inputs to Achieve Rail-to-Rail Outputs**

applicable to this demanding task. Figure 3 shows an LT1880 configured as a transimpedance photodiode amplifier. The transimpedance gain is set to 51.1k $\Omega$  by R<sub>F</sub>. The feedback capacitor, C<sub>F</sub>, may be as large as desired where response time is not an issue, or it may be selected for maximally flat response and highest possible bandwidth given a photodiode capacitance C<sub>D</sub>. Figure 4 shows a chart of C<sub>F</sub> and rise time versus C<sub>D</sub> for maximally flat response. Total output offset is below 262 $\mu$ V, worst-case, over temperature (0°C to 70°C). With a 5V output swing this implies a minimum 86dB dynamic range, sustained over temperature (0°C to 70°C), and a full-scale photodiode current of 98 $\mu$ A.

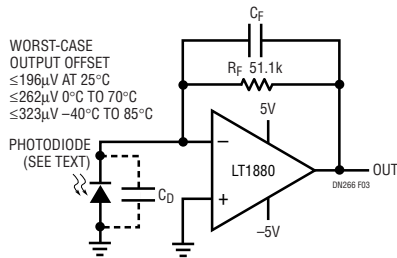

Figure 3. Precision Photodiode Amplifier

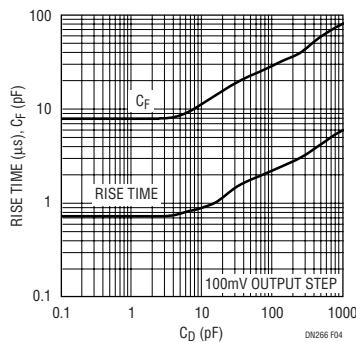

Figure 4. Feedback C<sub>F</sub> and Rise Time vs Photodiode C<sub>D</sub>

### Single-Supply Current Source for Platinum RTD

The precision, low bias current input stage of the LT1880 makes it ideal for precision integrators and current sources. Figure 5 shows the LT1880 providing a simple precision current source for a remote 1k $\Omega$  RTD on a 4-wire connection. The LT1634 reference places 1.25V at the noninverting input of the LT1880, which then maintains its inverting

input at the same voltage by driving 1mA of current through the RTD and the total 1.25k of resistance set by R1 and R2. Lower precision components R4 and C1 ensure circuit stability, which would otherwise be excessively dependant on the cable characteristics. R5 is also noncritical and is included to improve ESD immunity and decouple any cable capacitance from the LT1880's output. The 4-wire cable allows Kelvin sensing of the RTD voltage while excluding the cable IR drops from the voltage reading. With 1mA excitation, a 1k $\Omega$  RTD will have 1V across it at 0°C, and 3.85mV/°C temperature response. This voltage can be easily read in myriad ways, with the best method depending on the temperature region to be emphasized and the particular ADC that will be reading the voltage.

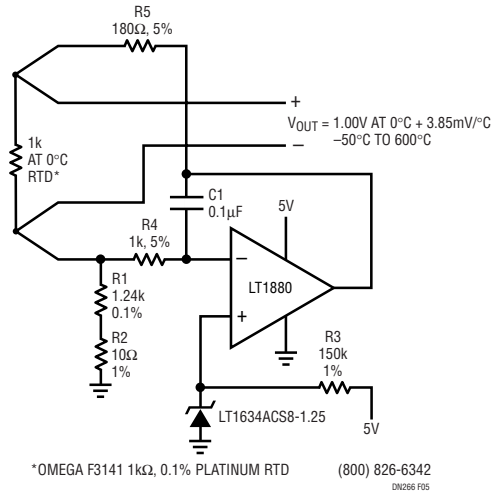

Figure 5. Single Supply Current Source for Platinum RTD

### CONCLUSION

The precision, low bias current input stage of the LT1880 makes it ideal for precision and high impedance circuits. The rail-to-rail output stage renders the op amp capable of driving other devices as simply as possible with extended dynamic range, while the 2.7V to 40V operation means that it will work on almost all supplies. The small SOT-23 package makes it a compelling choice where board space is at a premium or where a composite amplifier is competing against a larger single-chip solution.

### Data Sheet Download

<http://www.linear.com/go/dnLT1880>

For literature on our Precision Op Amps, call **1-800-4-LINEAR**. For applications help, call (408) 432-1900, Ext. 2156